

CTR17 – GENERAL TECHNICAL MANUAL

A) – Scope of the device

Electronic board controlling 1 or 2 110Vac or 220Vac single-phase asynchronous motors for the automation of a single or two-wing gate.

B) – Limits to use

Caution : Before operating the electronic unit make sure the following operations have been carried out.

Note 1 – Read carefully the whole technical documentation supplied.

Note 2 – The electronic unit must be installed by qualified personnel only. The installation engineer must have the necessary technical and professional qualification.

Note 3 – The mains power supply connected to the unit must be 110Vac or 220Vac +/- 10%.

Note 4 – The neutral (N) pole of the mains power supply must be unipotential to the ground on 110V units.
No neutral required on 220V units.

Note 5 – All security norms for the installation of electric and electronic devices must be respected.

Note 6 – The mains power must be supplied with an efficient differential switch tested and calibrated in conformity with the applicable rules.

Note 7 – Before installing the electronic unit check the motors to which it will be connected. When the motors are connected to the mains power the torque they apply to the gate must respect the applicable rules and, in any case, it must be such that in case of collision no damage will be caused to persons, animals or objects.

Note 8 – The unit must be applied for the intended use only (see point A). All other use is to be considered improper and dangerous.

Note 9 – Before acceding to the electronic unit's box for any intervention check that the mains power has been cut off.

Note 10 – Do not access the unit with wet/damp hand or feet.

Note 11 – Do not expose the unit to weather (rain, snow, etc.)

Note 12 – Do not allow any children or unqualified persons to touch the unit.

Note 13 – The electronic unit must be placed in the box supplied.

Note 14 – The plastic material used for the box is not self-extinguishing. Therefore it must be installed in an well aired place far from any objects or elements that can cause fire.

Note 15 – The ordinary maintenance of electronic unit must be executed by qualified personnel every 6 months.

Caution: Failure to respect the above listed norms can cause damage to persons, animals or objects. The manufacturer can in no way be held responsible for such damage.

C) – Installation

- 1) Unscrew the cover screws and lift the cover. Check that the electronic unit is in good order. In case of doubt do not install the unit and ask for the intervention of qualified personnel. The container's accessories (screws, round seal, cable glands) must not be left within the reach of children since they are a potential danger.
- 2) Check that the electronic unit is properly fixed to its box. If not, tighten all screws or provide the missing screws.
- 3) Place the unit near the gate so that the system connection wires' length is reduced to the minimum.

Caution: For the unit's correct operation the wires connected to it must not be longer than 10 metres.

- 4) For increased weather protection we recommend to place the unit under a roof or, even better, in an enclosure having two side walls. Wherever possible, it is advisable to install the unit at a minimum 1,5 mt level above the ground to keep it out of the reach of children.
- 5) Before proceeding to assembly place the container so that the side fitted with the cable glands is directed towards the ground.

Caution: Do not assemble the container on wood surfaces.

- 6) Insert the supplied round seal in its seat. Make sure the two ends meet at the centre of the side to which the cable glands are fitted.
- 7) Lift the mobile portion of the connector and proceed to connect the unit wires as described in the following chapters.

D) - Operation

1) Definitions of Controls

Start

Input connected to a push-button placed outside the unit. It is employed to request the gate's opening or closure (for both wings).

This input is usually connected to a key push-button.

Pedestrian Start

Input connected to a push-button placed outside the unit. It is employed to request the opening or closure of one wing only (pedestrian wing) to allow the passage of persons or animals.

2) Definitions of Safety devices

Stop

Input connected to a push-button or switch placed outside the unit. It is employed to cause the gate's immediate stop.

This control must be used in an emergency situation.

Photo-cell

Input connected to an optical barrier. It detects and signals the passage of persons or vehicles in the area crossed by the gate or in the nearby area.

Photostop

Input connected to an optical barrier. It detects and signals the passage of persons or vehicles in the area crossed by the gate or in the nearby area.

3) Definitions of Outputs

Blinker

Lamp's on/off control. The lamp functions as a warning and optical signaller of potential danger for the gate's motion.

Motor 1

Outputs for the opening/closure control of the motor which drives the first gate wing during the closing phase.

Motor 2

Outputs for the opening/closure control of the motor which drives the gate wing delayed during the closing phase. This wing is usually connected with an electric lock.

Electric lock

Impulse control for the electric lock release.

Courtesy light

Continuous control for the lamp which lights the area around the gate. The lamp is lit for approx. 2 minutes after the cycle has ended. During the pause before the gate closes back the lamp is lit in automatic mode or goes off in condominium mode.

Electrochain

Continuous control for the electric chain release. The control is enabled only during the motors' operation.

4) Definitions of Power Supply Inputs/Outputs

110Vac or 220Vac mains power

Input for the electronic board power supply.

24 Vac low voltage

Power supply output for the photo-cells and/or any other accessory devices.

1) Definitions of Accessory Inputs/Outputs

Aerial

Input for the connection of a radio receiving aerial. This input can only be used if a radio receiver card is connected to the unit.

2nd radio channel

Auxiliary control output. To be used only if a two-channel radio receiver card is connected to the unit.

2) Definitions of Optical Signals

LD6 – Photo-cell led (yellow)

It signals the optical barrier's state. The led goes off when the photo-cell is covered by persons or vehicles

LD4 – Photostop led (yellow)

It signals the optical barrier's state. The led goes off when the photo-cell is covered by persons or vehicles

LD5 – Stop led (red)

It signals the gate's block state. The led goes off when the stop control is operated (emergency).

LD2 – Start led (green)

It is lit when the start control is operated.

LD3 – Pedestrian start led (green)

It is lit when the pedestrian start control is operated.

LD1 – Power supply led (green)

It is lit when the electronic card power supply is present.

7) Definitions of Trimmers

RV1 - PAUSA - Pause

It defines the duration of the gate's pause before automatic closure.

RV2 - SFASAM. - M2 Delay

It defines the delay between the first wing's (M1) and the second wing's (M2) start during the closure phase.

- set to zero if on single gate application.

RV3 – LAVORO - Work time

It defines the motors' work time during the opening or closure phases.

8) Definitions of Dip Switches (Selection of Programs)

SW1 - Dip switch 1

It chooses whether the unit will operate in step-by-step mode or in automatic mode.

ON =Automatic OFF=Step by step

SW1 - Dip switch 2

It chooses whether the unit will operate in the mode determined by dip-switch 1 or in condominium mode.

ON=Codominium OFF=No effect

SW1 - Dip switch 3

It enables or excludes the **kickback** (during the opening phase with closed gate).

ON= Kickback enabled OFF=No effect

SW2 – Dip Fix

It determines the operation mode of the J7 auxiliary connector's output.

Closed Dip fix = electrochain mode Opened Dip Fix = courtesy light mode

9) Definitions of Protection Fuses

F1 – Mains power fuse 110V = 10amp, 222V = 5amp

It disconnects the electronic unit from the power supply mains in case of short-circuit or electric current consumption anomalies.

F2 – Low voltage fuse (2A)

It protects the electronic unit in case of short circuits or overcurrents on photo-cells, electric lock or any other accessory devices

connected to the 24Vac power supply.

10) Technical features

Torque Card - Power regulator

The electronic unit is pre-set for the optional connection of an accessory card called "power regulator". By means of this card the power supplied to the motors can be reduced.

Caution: In case failure or anomaly of the power regulator card the motors may operate at their maximum power value. This is why n° 7 note in the previous chapter "limits to use" must absolutely be put into practice.

Starting of maximum start up power

When any of the motors starts the unit supplies the maximum power value for approx. 1 sec. Subsequently the unit's power regulator card, if present, operates. This particular feature allows to overcome the high negative torque at the motors' start.

Radioreceiver

The electronic unit is pre-set for the optional connection of an accessory radio receiver card allowing remote control of the gate by means of the radio transmitter. The channel 1 of the radio receiver card ends with a non-polarized electric contact (relay) directly connected to the **start** input. The channel 2 of the radio receiver card ends with a non-polarized electric contact (relay) directly connected to the **2nd radio channel** output. This output is usually connected to the **pedestrian start** input, although it may be used also for other applications.

Blinker

The electronic card supplies an on/off control (flashing light) to the lamp. The logic of the blinking allows displaying the gate's operating.

Quick flashing light : it signals the opening phase

Slow flashing light : it signals the closing phase

Fixed light : it signals that the gate is blocked in pause before the closure phase in "automatic" mode.

The device supplies an on/off control (fixed light) to the lamp for approx. 1,5 sec. before the motors start (**pre-alarm**).

Work time

The motors' work time is controlled by two independent digital timers. For the automation system to work properly the operating time value to be set must be slightly (min. 2 sec.) above the gate's actual work time. If any command interrupts the wing's travel before its end, the Timer stops and the elapsed time is stored in memory. Therefore the unit can determine, with a fair approximation, the partial working time necessary to the wing to end its travel. Thanks to this feature it is possible to avoid that the motor works for a long time after the end of the wing's travel, thus reducing overheating to the minimum.

Warning : In case of absence of power supply the stored position will be lost.

Kickback

This procedure can be enabled or excluded. It is usually employed to help the electric lock release during bad weather conditions (wind, ice, etc.). The "**kickback**" procedure consists of a logic sequence operating the electric lock during a short closure phase (approx 1 sec.) with the gate closed. The electric lock is released only after the wing has started its opening motion.

M1 delay at opening

The unit causes a fixed delay of approx. 2 seconds between the first wing's (M2) and the second wing's (M1) start during the gate's opening phase. This delay is imposed irrespective of the position from which the gate starts to open. This delay may be cancelled by setting the **M2 delay** trimmer to its minimum value.

Warning: In case of single-wing gate it is necessary to set the **M2 delay** trimmer to its minimum value.

11) Operation modes

Introduction

The electronic unit contains a micro-processor to control the gate's operation modes. These are the three main operation phases :

Phase preceding the gate's motion

Gate's motion phase

Gate's pause phase (open gate)

The unit can function in three modes :

Step by step – This mode is enabled by setting the dip switches 1=OFF 2=OFF

Automatic – This mode is enabled by setting the dip switches 1=ON 2=OFF

Condominium– This mode is enabled by setting the dip switches 2=ON 1= No effect

The **Condominium** mode is the priority operation mode. If more than one modes are selected the priority mode will be enabled.

Notice: The operation logic setting (dip switch), the work time programming and the pause time programming must be carried out only if the cycle is concluded or before it starts (with closed gate).

The opening and closure cycles are enabled by a **Start** command.

Important : Whatever logic has been selected, the first Start command after the power is supplied to the electronic card will always cause the start of an opening cycle.

“Step-by-step” mode

After the power is supplied to the electronic card the first start command determines an opening cycle. At the end of the two work times, the gate stops. The operating cycle is completed (blinker off) and the system waits for a new start command to determine the closing cycle. If a start command is supplied when the end of travel has not been reached yet the gate stops. A new start command will cause the reversal of the motion.

“Automatic” mode

After the power is supplied to the electronic card the first start command determines an opening cycle. At the end of the two work times, the gate stops. The pause period starts (blinker on with fixed light). At the end of the pause period the gate closes automatically. The operating cycle is complete only when the closing motion has ended (blinker off). If a start command is supplied before the end of travel is reached the gate stops. A new start command will cause the gate to reverse its motion. If a start command is supplied during the pause period the operating cycle is interrupted (blinker off) and the gate does not close automatically. A further start command will determine a closing cycle.

“Condominium” mode

After the power is supplied to the electronic card the first start command determines an opening cycle. At the end of the two work times, the gate stops. The pause period starts (blinker off). At the end of the pause period the gate closes automatically. The operating cycle is complete only when the closing motion has ended. If a start command is supplied while the gate opens, the command will have no effect. If a start command is supplied while the gate closes, the gate will stop and reverse its motion after approx. 1.5 sec. If a start command is supplied during the pause period, the period will be reset and the automatic closure will start later.

Important : If the gate opening is controlled by a clock the “condominium” mode must be enabled.

Note : If dip switch 3=OFF the electric lock operates a split of second (0,8 sec) before the first wing (M2) starts , and stops operating a split of second (0,4 sec) after the wing's start.

In any operation mode, the safety devices causes the following effects :

Stop : If the stop command is enabled no cycles can start and the start command will have no effect. If a stop command is supplied during motion, the gate will immediately stop e interrupt its operating cycle. This condition will continue until the stop command is on. A start command following a stop command always determines an opening cycle. A stop command supplied during the pause period interrupts the operating cycle. A start command subsequently supplied will start a closure cycle.

Photo-cell : This device has effect only during the closure phase or in the pause period. If an obstacle covers the photo-cell during the closure phase , the gate stops and reverses its motion after approx. 1,5 sec. If an obstacle covers the photo-cell during the pause period this last one is reset and the automatic closure is therefore delayed.

Photostop : If an obstacle covers the photo-cell during the gate's motion (opening or closure), or during the period preceding the operating cycle's start, then the gate is temporarily stopped, until the obstacle is not removed. The blinker will light with a fixed light to signal the irregular condition. When the obstacle is removed and the photocell is freed, an opening cycle will start. This does not apply when a start command determines the closing phase in step-by-step mode at the end of an opening cycle. If an obstacle covers the photostop during the pause period this last one is reset and the automatic closure is therefore delayed.

Pedestrian start: The pedestrian start command operates in the same way as the other start command, but in this case only the wing fitted with the electric lock (M2) will be opened or closed. The pedestrian start command has no effect during a start cycle and up to the end of the closing phase (closed gate). During a pedestrian start cycle the start command is always active.

12) Electrical and mechanical specifications

Dimensions and weight : 177 x 247 x 92 mm - 1,3 Kg
Mains power supply : 110 Vac or 220Vac +/- 10%
Stand-by power consumption : approx. 1 W
Operating temperature range : 0 to + 60 °C
Single-phase motors power supply : 110Vac or 220Vac 1 HP max
Blinker power supply : 110Vac or 220Vac 40 W max
Courtesy light power supply : 110Vac or 220Vac 40 W max
Electric lock power supply : 12 Vac 15 W max
Accessories power supply : 24 Vac 6 W max
2nd radio channel relay contact : 24 Vac 0,5 A max
Motors' work time : programmable, 0 to 100 sec.
Pause time : programmable, 2 to 100 sec.
2nd wing closing delay : programmable, 0 to 25 sec.

Caution : The unit must be not switched on if the connected loads or the power supply exceed the a.m. limits. Failure to observe this precaution can result in damage to persons, animals or objects for which the manufacturer cannot be held responsible.

13) Electric connections

6 electric connectors are fitted to the card :

- 1) **J5** 10-pole Terminal board for the connection of the devices operating with 110Vac mains power supply (motors, blinker, mains cable).
- 2) **J6** 10-pole Terminal board for the connection of the devices operating at low voltage (commands, safety devices, electric lock and 24Vac power supply output)
- 3) **J4** 4-pole Terminal board for the connection of the auxiliary devices operating at low voltage (aerial and 2nd radio channel output)
- 4) **J7** 2-pole Terminal board for the connection of the auxiliary devices operating with 110Vac mains power supply (courtesy light or electric chain)
- 5) **J3** 4-pole connector for the optional connection of a power regulator card
- 6) **J2** 10-pole connector for the optional connection of a radio receiver card

Terminal board J5

Terminal1 - 110 Vac or 220Vac mains power supply phase

Terminal2 - 110 Vac or 220Vac mains power supply neutral

Warning: The power supply voltage polarities must be carefully observed.

Terminal3 - 110 Vac or 220Vac motor M1 power supply phase (opening)

Terminal4 - 110 Vac or 220Vac motor M1 power supply phase (closure)

Terminal5 - 110 Vac or 220Vac motor M1 Power supply common

Note: connect the capacitor of the motor M1 between terminals 3 and 4

Terminal6 - 110 Vac or 220Vac motor M2 power supply phase (opening)

Terminal7 - 110 Vac or 220Vac motor M2 power supply phase (closure)

Terminal8 - 110Vac or 220Vac motor M2 Power supply common

Note: connect the capacitor of the motor M2 between terminals 6 and 7

Terminal9 - 110 Vac or 220Vac blinker power supply phase

Terminal10 - 110 Vac or 220Vac blinker power supply neutral

Terminal board J6

Terminal1 – Electric lock 12 Vac power supply

Terminal2 – Electric lock 12 Vac power supply (common)

Terminal3 – 24Vac power supply for photo-cells or other devices (common)

Terminal4 – 24Vac power supply for photo-cells or other devices

Terminal5 – Common terminal for all electric contacts of commands or security devices

Terminal6 – Photo-cell's normally closed electric contact

Terminal7 – Emergency push-button's normally closed electric contact (stop)

Terminal8 – Photoelectric cell's normally closed electric contact (photostop)

Terminal9 – Start push-button's normally open electric contact

Terminal10– Pedestrian start push-button's normally open electric contact

Important: The normally closed inputs not in use must be fitted with jumpers

Terminal board J4

Terminal1 – 2nd radio-channel's normally open electric contact (output)

Terminal2 – 2nd radio-channel's normally open electric contact (output)

Terminal3 – Aerial cable connection (shield) for radio receiver card

Terminal4 – Aerial cable connection (signal) for radio receiver card

Terminal board J7

Terminal1 – Courtesy light's or electric chain's 110Vac or 220Vac power supply phase

Terminal2 – Courtesy light's or electric chain's 110Vac or 220Vac power supply neutral

Connector J3

Terminal1 – 110 Vac or 220Vac motors M1 and M2 Power supply common

Terminal2 – 110 Vac or 220Vac motors M1 and M2 Power supply common

Terminal3 – 110 Vac or 220Vac motors M1 and M2 Power supply common

Terminal4 – 110 Vac or 220Vac mains power supply neutral

Important: If the power regulator card is not connected the J3 connector's terminals 3 and 4 must be bridged with 4 mm insulated faston terminal

Connector J2

Terminal1 – Normally open electric contact connected to the start

Terminal2 – Common of the normally open electric contact connected to the start

Terminal3 – Normally open electric contact connected to the 2nd radio-channel output

Terminal4 – Normally open electric contact connected to the 2nd radio-channel output

Terminal5 – 24Vac power supply (common)

Terminal6 – 24Vac power supply

Terminal7 – 24Vac power supply

Terminal8 – 24Vac power supply (common)

Terminal9 – Aerial input (shield)

Terminal10 – Aerial input (signal)

Connection of the devices

110Vac or 220Vac mains power supply cable – Terminals 1 and 2 on J5

Warning: The cable's ground pole must be connected to a good ground reference in the gate's nearby area.

Motor 1 – Terminals 3, 4 and 5 on J5

Motor 2 – Terminals 6, 7 and 8 on J5

Blinker – Terminals 9 and 10 on J5

Electric lock – Terminals 1 and 2 on J6

Photo-cells power supply – Terminals 3 and 4 on J6

NC photo-cell contact – Terminals 5 and 6 on J6

NC stop push-button – Terminals 5 and 7 on J6

NC photostop contact – Terminals 5 and 8 on J6

NO pedestrian start push-button – Terminals 5 and 9 on J6

NO start push-button – Terminals 5 and 10 on J6

Aerial – Terminals 3 and 4 on J4

Courtesy light – Terminals 1 and 2 on J7

Electrochain – Terminals 1 and 2 on J7

Important: Before starting the gate check all connections to the electronic card. Check also the electric contacts' switching, which is signalled by the leds' operation.

CONFORMITY DECLARATION

To EMC directive EN45014 and ISO guide 22

Company name and registered office :

G.E.M. Fabrications Ltd.
308 Fitzwilliam St.
Nanaimo B.C. V9R 3A5

Description of the appliance :

Electronic board for the control of 1 or 2 110Vac or 220Vac single-phase asynchronous motors for gate automation.

Model : **CTR17.04**

Reference rules applied : **EN 50081-1, EN 50082-1, EN 55014**

Basic rules applied : **EN 61000-3-2
EN 61000-3-3
EN 61000-4-4
EN 61000-4-2
ENV 50140**

Test laboratory : **Intek s.p.a.**

Outcome : **Positive**

The manufacturer declares that the above listed products comply to the norms on electromagnetic compatibility provided for by directives 89/336/EEC, 92/31/EEC, 93/68/EEC.

Date , **01-01-2000**

General diagram

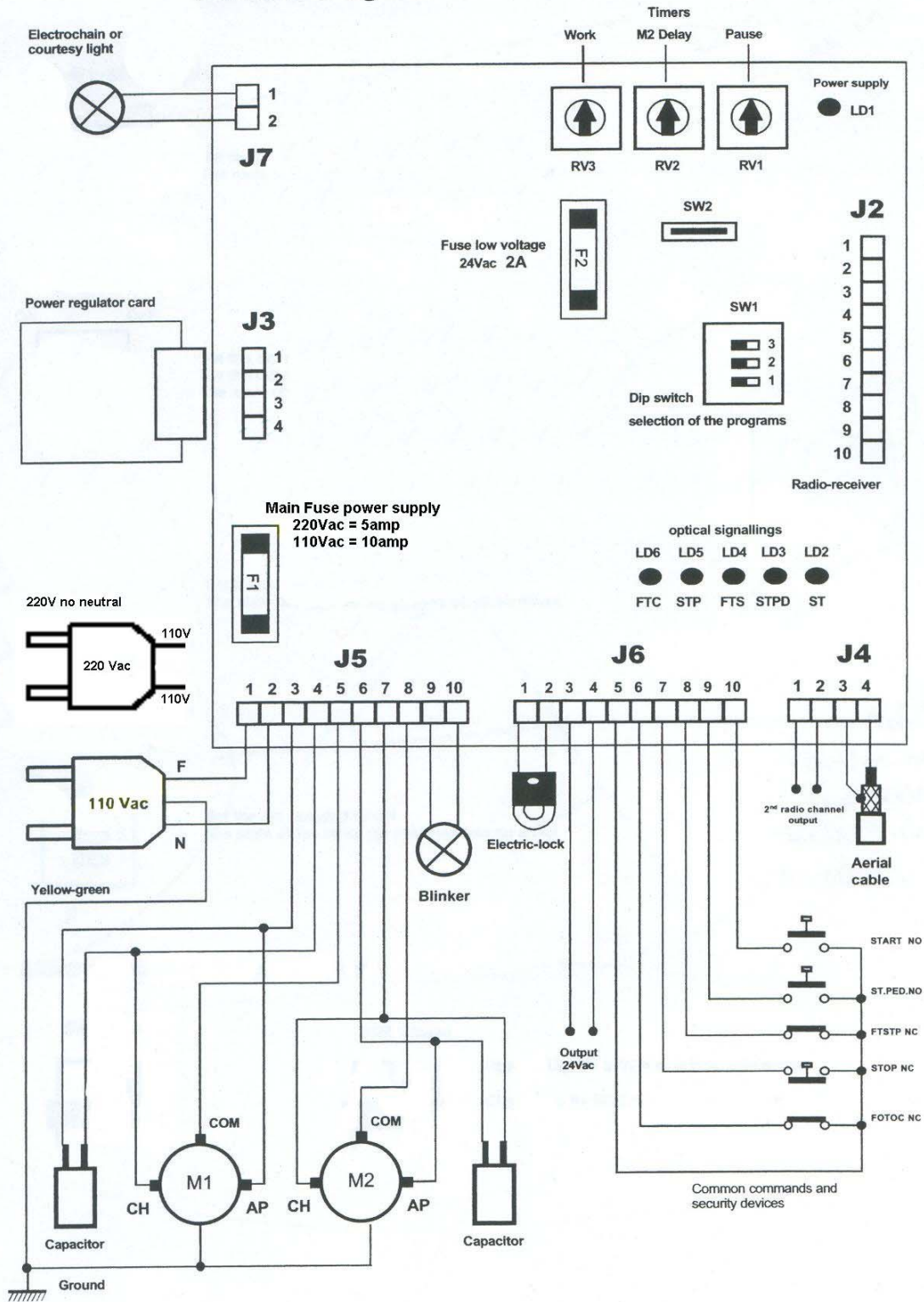

Programming the card

Step-by-step logic

ON OFF



Set the dip switches 1 and 2 to OFF
The state of the other dip switches has no effect

Automatic logic

ON OFF



Set the dip switch 2 to OFF
Set the dip switch 1 to ON
The state of the other dip switches has no effect

Condominium logic

ON OFF



Set the dip switch 2 to ON
The state of the other dip switches has no effect

Kickback logic

ON OFF

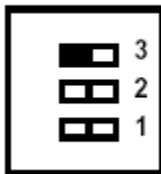

Set the dip switch 3 to ON
The state of the other dip switches has no effect

Electrochain / courtesy light logic

SW2 Opened



SW2 Closed



Opened Dip Fix SW2 =
courtesy light mode

Closed Dip fix SW2 =
electrochain mode